

## A NEW TECHNOLOGICAL STEP FOR SiC MIRRORS PREPARING OTOS

M. Bougoin<sup>1</sup>, J. Lavenac<sup>1</sup>, C. Coatantiec<sup>2</sup>, V. Costes<sup>3</sup>

<sup>1</sup>Boostec (Mersen group), Bazet, France. [michel.bougoin@mersen.com](mailto:michel.bougoin@mersen.com) [Jerome.lavenac@mersen.com](mailto:Jerome.lavenac@mersen.com)

<sup>2</sup>Airbus Defence & Space, France [claude.coatantiec@astrium.eads.net](mailto:claude.coatantiec@astrium.eads.net).

<sup>3</sup>CNES, France [vincent.costes@cnes.fr](mailto:vincent.costes@cnes.fr)

### I. INTRODUCTION

OTOS is a DGA and CNES technology program dedicated to the preparation of the next generation space telescopes. In this frame, adaptive optics demonstration is one of the main purposes and the development of a 1.5m extremely lightweight SiC mirror is a key technological development. As a mock-up, BOOSTEC has manufactured a 0.52m SiC mirror. The Boostec<sup>®</sup> SiC material is used mainly for its high specific stiffness (Young's modulus / density) and its high thermal conductivity / coefficient of thermal expansion ratio which permit to reduce the distortions induced by thermo-elastic stresses at the telescope level. The mirrors optical face is generally clad with a fully pore-free SiC CVD layer, a few hundred micrometers thick, thus minimizing scattering and its contribution to stray light.

For OTOS, AIRBUS Defence & Space has designed and is developing a new concept of primary mirror based on Boostec<sup>®</sup> SiC technology. This primary mirror is extremely lightweight (# 16.5kg/m<sup>2</sup>) and requires innovative manufacturing approach, in particular: i) machining very thin ribs and face sheet (down to 1.25mm), ii) SiC CVD cladding on very thin SiC blank, iii) brazing assembly of former SiC CVD clad segments, iv) risk mitigated manufacturing thanks to segmented approach.

This innovative manufacturing technology has been developed and demonstrated by BOOSTEC through a 0.52m technological mock-up, made of 2 brazed segments. Such a brazing approach has been successfully used for Herschel 3.5m primary mirror but without any SiC CVD cladding. BOOSTEC is now able to manufacture very large mirrors (>1.5m) for optical applications.

### II. Boostec<sup>®</sup> SiC MATERIAL FOR MIRRORS

BOOSTEC manufactures a **sintered silicon carbide** which is named **Boostec<sup>®</sup> SiC**. Its key properties are a high specific stiffness (420GPa / 3.15g.cm<sup>-3</sup>) combined with a high thermal stability (180W.m<sup>-1</sup>.K<sup>-1</sup> / 2.2 . 10<sup>-6</sup> K<sup>-1</sup>).

Its high mechanical strength allows making structural parts.

Thanks to its isotropic microstructure, the physical properties of this alpha type SiC are perfectly isotropic and reproducible inside a same large part or from batch to batch. In particular, no CTE mismatch has been measurable, with accuracy in the range of 10<sup>-9</sup>K<sup>-1</sup> [1].

The CTE of Boostec<sup>®</sup> SiC is decreasing from 2.2 . 10<sup>-6</sup> K<sup>-1</sup> @ room temperature down to 0.2 . 10<sup>-6</sup> K<sup>-1</sup> @ 100K and close to zero between 0 and 35K. Its thermal conductivity remains over 150W/m.K in the 70K-360K temperature range.

This material shows no mechanical fatigue, no outgassing and no moisture absorption nor release. It has been fully qualified for space application at cryogenic temperature such as NIRSpec instrument which will be operated at only 30K [2].

It shows a better stability in time and a better resistance to the space radiations than the glass-ceramics which have also been commonly used for space mirrors.

TABLE I. BASIC PROPERTIES OF BOOSTEC<sup>®</sup> SiC

Properties	Typical Values @ 293 K
Density	3.15 g.cm <sup>-3</sup>
Young's modulus	420 GPa
Bending strength / Weibull modulus (coaxial double ring bending test)	400 MPa / 11
Poisson's ratio	0.17
Toughness (K <sub>1C</sub> )	3.5 MPa.m <sup>1/2</sup>
Coefficient of Thermal Expansion (CTE)	2.2 . 10 <sup>-6</sup> K <sup>-1</sup>
Thermal Conductivity	180 W.m <sup>-1</sup> .K <sup>-1</sup>
Electrical conductivity	10 <sup>5</sup> Ω.m

The Boostec<sup>®</sup> SiC can be easily polished as it is single phased. Thanks to its high purity, its coefficient of thermal expansion (CTE) fits very well with the one of the extremely pure CVD SiC; this last one is obtained from chemical vapor deposition and it is commonly applied on the optical faces of SiC mirrors, in the aim to mask the few remaining porosities, when necessary. Such a SiC CVD cladding is required for OTOS mirrors.

### III. Boostec<sup>®</sup> SiC MANUFACTURING TECHNOLOGY FOR MIRRORS

The SiC CVD cladding which is presented here after is dedicated to the mirrors, when necessary. The other technologies are used for manufacturing the mirrors but also the telescopes structures.

#### A. Manufacturing monolithic SiC parts

Commonly, BOOSTEC manufactures monolithic SiC parts of up to 1.7m x 1.2m x 0.6m (or  $\Phi$ 1.25m). The flight models are manufactured with the sequence of steps detailed in Fig. 1. The parts are machined very close to the final shape at the green stage i.e. when the material is still very soft (similar to chalk). This is high speed machining; typically, green parts of 1 meter are machined within only 1 week. Furthermore, in BOOSTEC process, the collected chips are reused for producing new raw material. During the last ten years, the reliability and also the speed of this process have been continuously improved. New software has been invested for programming the CNC milling machines and also to verify the machining programs, thus allowing the green machining of very complex 3D shapes with a high reliability. These are some of the reasons why BOOSTEC process is so cost effective, reliable and quick.

These shaped parts are then sintered by heating-up to around 2100°C under a protective atmosphere, thus transforming the compacted powder blank into a hard and stiff ceramic material. The “as-sintered” surfaces look highly smooth (typically Ra 0.4µm); they can be used as is, without any sand blasting or any other rework. The optical faces of the mirrors and also the interfaces of the structures are then generally ground in order to obtain accurate shape (from 1µm up to 50µm) and location; they are optionally further lapped or polished for an even better accuracy and a smaller roughness.

The mechanically loaded parts are generally proof-tested in order to avoid defects which could be hidden in the material; even if unlikely, this is above all an easy way to really prove that the relevant SiC part is able to withstand with the predicted most critical loads. The parts are checked crack-free with help of UV fluorescent dye penetrant, before and after such a proof-test. They are measured with a large size accurate CMM or a laser tracker.

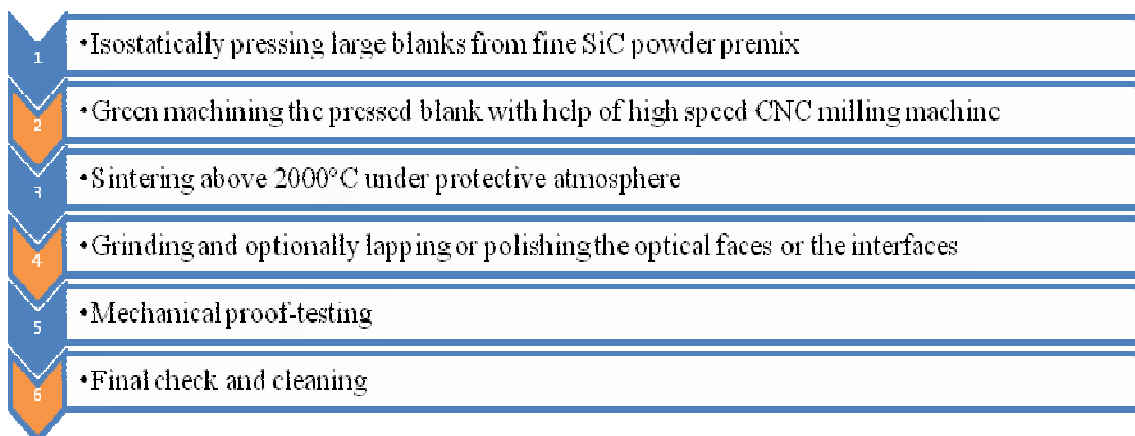

Fig. 1. Manufacturing process for monolithic sintered SiC parts

### B. Manufacturing very large SiC parts

The SiC parts the size of which exceeds about 1.7m x 1.2m x 0.4m are obtained by **brazing** the assembly of previously sintered and ground pieces. The joint is made of a silicon alloy and it is generally less than 0.05mm thick. The SiC parts are all joined together in a single run; their relative location is kept better than +/- 0.1mm from the prediction to the final measurement, at the end of the brazing process.

This process has been developed a decade ago for the  $\Phi$  3.5m Herschel primary mirror which is made of 12 SiC segments brazed together [3] [5]. Since that, it has been successfully used for the assembly of the  $\Phi$  3.0m Gaia torus [4] [5] and the main structure of Sentinel-2 MSI [6]. The brazed joints are checked with help of ultrasound technique which allows to detect possible braze voids down to a few mm<sup>2</sup>.

### C. SiC CVD cladding

In close collaboration with MERSEN France Gennevilliers, its affiliated company, BOOSTEC is now able to offer a SiC CVD cladding on its mirror blanks. Various kinds of small mirrors which are widely used in the photonics industry have been successfully clad in "Gennevilliers" furnaces since 2011, at series level. Final product characteristics are good cladding homogeneity, reproducible thickness and crystallisation, good cosmetic aspect (SiC-like grey colour obtained) and good ability to further polishing. On the other hand, the process has been qualified for large size ( $\Phi$  1.2m) space mirrors and it will be used for OTOS program. Another important requirement on these industrial or space mirrors is the saving of un-coated zones (generally mirror's backside). BOOSTEC is capable of mounting additional tooling to prevent from SiC deposition on desired areas.

## IV. EXPERIENCE IN LARGE SPACE SiC MIRRORS

From the Osiris NAC camera which is now sending outstanding pictures of the "Chury" comet up to GAIA which has been commissioned recently, BOOSTEC has successfully manufactured the hardware of a lot of space telescopes fully made of SiC, in close collaboration with AIRBUS Defence & Space teams [7]. Mid 2014, 14 of those are (or has been for Herschel case) successfully operating in space. Their mirrors are made of Boostec<sup>®</sup> SiC but it is also the case for their structure and, for some of them, the hardware of their focal plane.

The Herschel primary mirror and the GAIA ones illustrate BOOSTEC state of the art before starting the present development program. These examples which are developed here after show that BOOSTEC is able to manufacture i) very large and lightweight mirrors (up to  $\Phi$  3.5m) by brazing up to 12 segments, but without CVD cladding, ii) large and lightweight monolithic mirror blanks, aspheric and possibly off-axis, including SiC CVD cladding. The aim of the present development is to push and to combine these technologies in order to obtain extremely lightweight mirrors made of brazed segments and including SiC CVD cladding.

### A. Herschel M1 [3] [5]



Fig. 2. Herschel a) rear face of brazed primary mirror and b) final telescope assembly

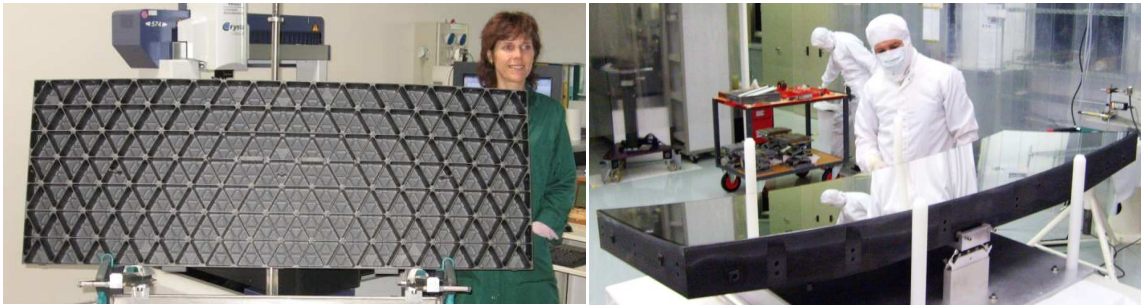

**Fig. 3.** Detailed view of the rear face of HERSCHEL  $\Phi$  3.5m primary mirror, including an interface

The Herschel primary mirror has been obtained from 12 SiC segments brazed together (Fig. 2); 3 of them included an interface ready to be bolted with bipods (Fig. 3). The M1 optical face sheet is stiffened by a network of 4 to 8mm thick main ribs and 1.5 to 2.0 mm thick sub-ribs. Its aerial density is only 25kg/m<sup>2</sup>. After brazing, the parabola (3.49m RoC) has been ground down to a shape defect of 150  $\mu$ m PTV. It has then been polished by OPTEON (Finland) down to 3 $\mu$ m rms WFE and coated with aluminum and a protective Plasil at CALAR ALTO (Spain). No SiC CVD was required here as this M1 reflects far-infrared to sub-millimetric wavelengths.

#### *B. GAIA primary mirrors [4] [5]*

The primary mirrors of the 2 GAIA Astro TMAs are aspheric and off-axis. They were quite challenging due to their large size (1.50m x 0.56m) and their huge number of back side cells which form a network of thin ribs and sub-ribs (Fig. 4). These mirror blanks weight only 38kg. After SiC CVD cladding their optical face, they have been successfully polished to a precision of about 10nm rms and coated with protective silver by REOSC.



**Fig. 4.** Views of a GAIA primary mirror a) rear face and b) after polishing and coating at REOSC

#### V. OTOS PROGRAM

After the successful launch of the two Pleiades satellites in 2011 and 2012, DGA and CNES are now preparing the future generation of very high resolution optical Earth observation systems. Within the frame of a technology program, named OTOS, many new technological developments leading to very compact and low cost satellites are on-going. For this next satellite generation, DGA and CNES are looking for very compact and lightweight telescopes. The preliminary telescope studies clearly demonstrated the stringent optical sensitivity and the stringent mechanical requirements and lead to the conclusion that adaptive optics should be required [8]. Implementing adaptive optics permits to optimize the design of the primary mirror and to reduce drastically its mass.

In the frame of OTOS, technological demonstrators are developed by industrial partners. Adaptive optics demonstration is one of the main purposes in which a 1.5m extremely lightweight SiC mirror is developed by BOOSTEC under AIRBUS Defence & Space contract.

## VI. SiC MIRROR DESIGN FOR OTOS

AIRBUS Defence & Space has designed a very lightweight mirror of 1.5 meters in diameter, to be manufactured as a demonstrator in a second step. A smaller (0.52m) mock-up with scale 1 for cells and thickness has been extracted from the former design and manufactured. This first step has permitted to investigate and to validate the technological innovations.

### A. $\varnothing$ 1.5m Mirror Demonstrator

The  $\varnothing$  1.5m demonstrator features

- 6 brazed segments,
- a triangular network of very thin ribs and sub-ribs,
- 1.9mm thick optical face sheet, including 0.4mm thick CVD,
- spherical concave optical face,  $R_c = 3600\text{mm}$

With BOOSTEC technology and facilities, the “6 time 60° segments” concept allows to manufacturing brazed mirrors of 1.3 m up to 2.5 m in diameter, thus covering the potential need for OTOS. It is also very interesting on risk mitigation purpose: before brazing the assembly, a damaged segment can be easily replaced by a spare one. Smaller mirror blanks should be made monolithic.

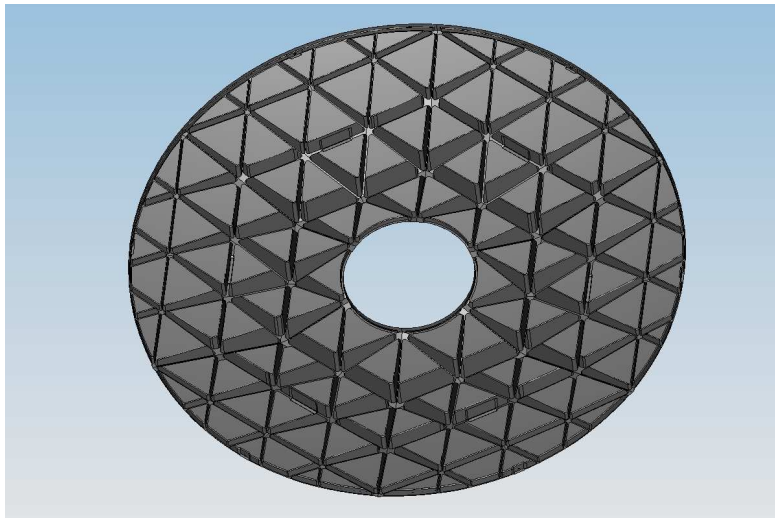

Fig. 5. CAD model of the  $\varnothing$  1.5m demonstrator

### B. Mock-up

The 0.52m mock-up features similarly

- 2 brazed segments; the 2 segments are perfectly the same,
- hexagonal outline, 520mm between opposite corners,
- a triangular network of very thin ribs and sub-ribs (in only 2 cells),
- 1.9mm thick optical face sheet, including 0.4mm thick CVD,
- spherical concave optical face,  $R_c = 4500\text{mm}$
- 3 glued invar interfaces including helicoids,
- 3.4kg total weight including invar pads, equivalent to an aerial density of  $16.5\text{kg/m}^2$  on the only SiC part.

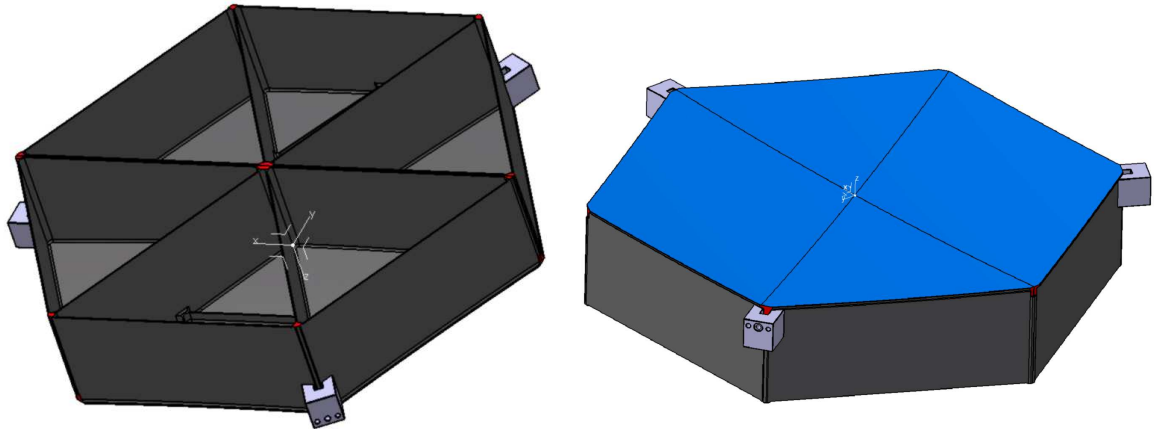

Fig. 6. CAD model of the 0.52m mock-up a) rear face and b) optical face

## VII. DEVELOPPING AND MANUFACTURING A 0.52m SiC MOCK-UP

The general mock-up manufacturing sequence is presented in Fig. 7.

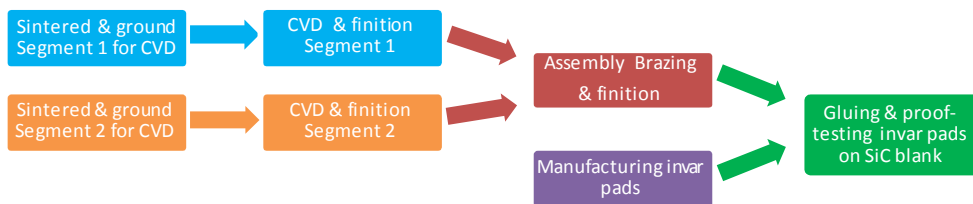

Fig. 7. Manufacturing sequence of the 0.52m mock-up

### A. Manufacturing sintered and ground segments

Each segment has been machined from a block of pressed powder, sintered, ground, measured and checked crack free.

At this stage, the main challenges were ...

- i) green machining very thin and large ribs,
- ii) green machining small radius at each pocket corner (R4 for 100mm deep pockets),
- iii) grinding the optical face sheet with a thickness of only 1.5mm (taking into account the following addition of 0.4mm thick CVD cladding).

Both segments 1 & 2 have been successfully manufactured; they have been checked crack-free, without any significant deformation at sintering level and also without any significant quilting of the optical face sheet.

### B. CVD cladding and finishing the segments

The 2 segments have been CVD clad in one of the large furnaces of MERSEN Gennevilliers but in 2 different runs, thus being representative of industrial condition for a large mirror; the “Gennevilliers” furnaces would be large enough for cladding the segments of  $\varnothing$  2.50m mirrors. Furthermore, BOOSTEC developed and mounted specific additional tooling to prevent from SiC deposition on all back side areas (ribs, sub-ribs and rear face). Taking into account the small thickness of all areas, it was also quite challenging.

After having dismantled these savings, the blanks have been ground in order to prepare them for the next step, brazing the assembly.

The ready to braze blanks have been checked crack-free, with a minimum CVD thickness very close to the 0.40mm target.

### *C. Brazing and finishing the assembly*

Taking into account BOOSTEC experience in brazing very large and complex SiC parts, the main challenge here was the alignment of the “substrate” optical faces (i.e. the interface between sintered SiC and SiC CVD layer). Better alignment at this stage gives better homogeneity of the CVD layer thickness on the final mirror. The final measurement showed no significant alignment error and no deviation during the brazing process. The brazed assembly has been furthermore ground in order to obtain i) an optical face with required shape and CVD thickness and ii) accurate lateral interfaces. The brazed joint has been checked free of brazed voids with help of ultrasound technique. The SiC blank has been also checked crack-free at this stage.

### *D. Gluing and proof-testing the invar pads on the SiC blank*

As required by REOSC for purpose of mounting the mock-up on their polishing facilities, 3 invar pads including helicoils have been epoxy glued. The mechanical strength of the assembly has been validated with help of a simple mechanical proof-test.

### *E. Main characteristics of the final mock-up, ready for polishing (Fig. 8)*

All measurements have been checked in conformity with the drawing. We can mention in particular,

- spherical optical face Rc # 4500 mm with shape defect of 0.044mm PTV (specified < 0.05mm),
- optical face thickness comprised between 1.83 and 2.04mm (specified @ 1.90 +/- 0.25mm),
- SiC CVD thickness comprised between 0.35 and 0.41mm (specified @ 0.40 +/- 0.10mm),
- weight # 3.46kg (expected 3.4kg).

This “ready to polish” mock-up has been delivered to REOSC in early January 2014. Its polishing is in good progress.

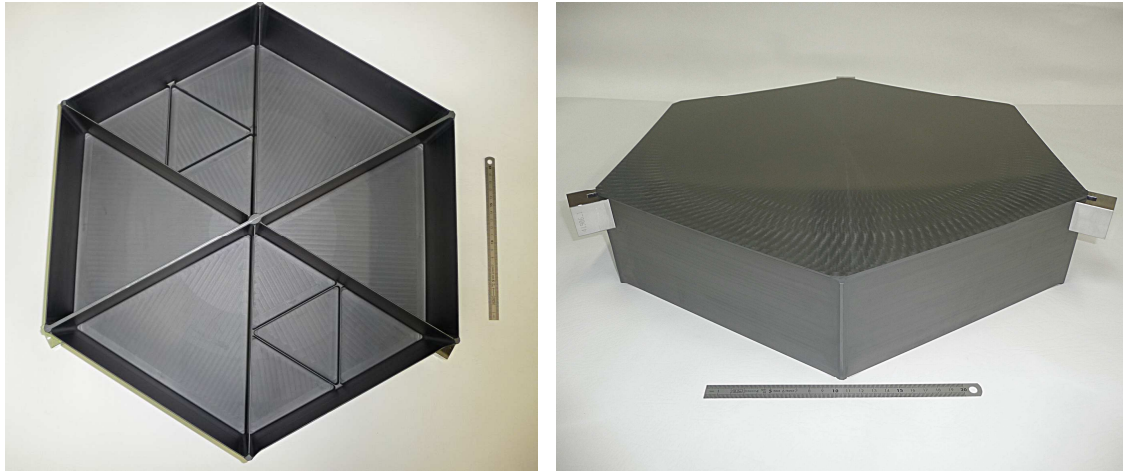

**Fig. 8.** Views of the mock-up, as delivered by BOOSTEC a) rear face and b) optical face

## VIII. CONCLUSION

In the frame of OTOS, DGA and CNES technology program, BOOSTEC and AIRBUS Defence & Space are developing a new concept of extremely lightweight optical mirrors. This concept is breaking down the barrier of the manufacture of monolithic optical mirrors. It is capable of mirror diameter of 1.5m and far beyond.

A 1.5m diameter mirror has been designed by AIRBUS Defence & Space. It is a 6 brazed segments mirror. A first mock-up has been successfully manufactured by Boostec, with an aerial density of only 16.5kg/m<sup>2</sup>. It has validated the very new sequences of this brazed optical mirror concept. The manufacture of the 1.5m mirror is on-going.

REFERENCES

- [1] M. Bougoin, D. Castel, F. Levallois, "CTE homogeneity, isotropy and reproducibility in large parts made of sintered SiC", *Proceedings of ICSO 2012 (International Conference on Space Optics)*, Ajaccio, France, Oct. 9-12, 2012
- [2] K. Honnen, A. Kommer, B. Messerschmidt, T. Wiehe, "NIRSpec OA development process of SiC components", *Advanced Optical and Mechanical Technologies in Telescopes and Instrumentation*. Edited by Atad-Etiedgui, Eli; Lemke, Dietrich. *Proceedings of the SPIE*, Volume 7018, 2008.
- [3] Y Toulemont, T.Passvogel, G.Pillbrat, D. De Chambure, D.Pierot, D.Castel, « the 3.5m all SiC telescope for Herschel », *Proceedings of the 5th International Conference on Space Optics (ICSO 2004)*, 30 March - 2 April 2004, Toulouse, France. Ed.: B. Warmbein. ESA SP-554, Noordwijk, Netherlands: *ESA Publications Division*, ISBN 92-9092-865-4, 2004, p. 341 – 348
- [4] P. Charvet, F. Chassat, F. SAFA, G. SARRI, "GAIA payload module description", *Sixth International Conference on Space Optics, Proceedings of ESA/CNES ICSO 2006, held 27-30 June 2006 at ESTEC*, Noordwijk, The Netherlands. *Edited by A. Wilson*. ESA SP-621. European Space Agency, 2006.
- [5] M. Bougoin , J. Lavenac, "From HERSCHEL to GAIA, 3-meter class SiC space optics", *Optical Manufacturing and Testing IX*. Edited by Burge, James H.; Föhnle, Oliver W.; Williamson, Ray. *Proceedings of the SPIE*, Volume 8126, (2011)
- [6] M. Bougoin, J. Lavenac, "The SiC hardware of the Sentinel-2 Multi Spectral Instrument", *Proceedings of ICSO 2012 (International Conference on Space Optics)*, Ajaccio, France, Oct. 9-12, 2012
- [7] J. Breysse, D. Castel, M. Bougoin, "All SiC telescope technology at EADS Astrium – Big step forward for space optical payloads", *Proceedings of ICSO 2012 (International Conference on Space Optics)*, Ajaccio, France, Oct. 9-12, 2012
- [8] V. Costes, D. Laubier, P. Darré, L. Perret, "Optical design and active optics for next generation space telescopes", *Proceedings of the SPIE*, Conference Volume 8860, (2013)